

## ABSOLUTE ROTARY ENCODER SSI



### Main Features

- Compact and heavy-duty industrial model
- Interface: Synchronous-serial (RS 422)
- Housing: 58 mm Ø
- Shaft: 6 or 10 mm Ø
- Hollow shaft 12 mm Ø
- Blind hollow shaft 15 mm Ø
- Max. 65,536 steps per revolution (16 bit)
- Max. 16,384 revolution (14 bit)
- Preset input / Incremental output (optional)
- Code: Gray or Binary
- EMC: EN 61000-6-2, EN 61000-6-4

### Mechanical Structure

- Aluminum flange and housing
- Stainless steel shaft
- Precision ball bearings with sealing or cover rings
- Code disc made of unbreakable and durable plastic

### Applications

- Sensing of
- Angles
- Distances
- Tracks
- Inclinations
- Differences between two or more axes

### Electrical Features

- Temperature insensitive IR-opto-receiver-ASIC with integrated signal conditioning
- Only one IR-transmitter-diode per opto-ASIC
- Highly integrated circuit in SMD -technology
- Polarity inversion protection
- Over-voltage-peak protection

### SCANCON A/S

Tranevang 1, 3450 Allerød, Denmark  
Tel: +45 48172702 Fax: +45 48172284  
info@scancon.dk www.scancon.dk



## ABSOLUTE ROTARY ENCODER SSI

### Technical data

#### Electrical data

Clock input	Via opto-coupler
Data output	Line-driver according to RS 422
Clock frequency	100 kHz - 2 MHz
Step frequency LSB	Max. 800 kHz (internal)
Accuracy of division	$\pm \frac{1}{2}$ LSB (12 bit), $\pm 2$ LSB (16 bit)
Supply voltage	10-30 V DC (absolute limits) *
Cycle time (Preset)	> 150 $\mu$ s (only interface S1, S3, S4)
Turn on time	< 1 s
Power consumption	Interface SL / S1 / S4 max. 1 W; interface S2 / S3 max. 1.5 W
Electrical lifetime	> 10 <sup>9</sup> h
EMC	Emitted interference: EN 61000-6-4
	Noise immunity: EN 61000-6-2
Connection	Connector or cable exit 1m

\* Supply voltage according to EN 50 178 (safety extra-low voltage)

#### Mechanical data

Housing	Aluminum, optional stainless steel				
Lifetime	Dependent on shaft version and shaft loading – refer to table				
Max. shaft loading	Axial 40 N, radial 110 N				
Inertia of rotor	$\leq 30 \text{ gcm}^2$				
Friction torque	$\leq 3 \text{ Ncm}$ (without shaft sealing)				
RPM (continuous operation)	Max. 12,000 RPM, Hollow shaft (T): max. 3,000 RPM				
Shock (EN 60068-2-27)	$\leq 100 \text{ g}$ (half sine, 6 ms)				
Permanent shock (EN 60028-2-29)	$\leq 10 \text{ g}$ (half sine, 16 ms)				
Vibration (EN 60068-2-6)	$\leq 10 \text{ g}$ (10 Hz ... 1,000 Hz)				
Weight (standard version)	Single turn:	$\approx 200 \text{ g}$			Single turn Hollow shaft (T): 300 g
	Multi turn:	$\approx 300 \text{ g}$			
Weight (stainless steel version)	Single turn:	$\approx 400 \text{ g}$			Single turn Hollowshaft (T): 600 g
	Multi turn:	$\approx 600 \text{ g}$			
<b>Flange</b>	<b>Synchro (S)</b>		<b>Clamp (C)</b>	<b>Blind hollow shaft (B)</b>	<b>Hollow shaft (T)</b>
Shaft diameter	6 mm	10 mm	10 mm	15 mm	12 mm
Shaft length	10 mm	20 mm	20 mm	-	-
Hollow shaft depth min. / max.	-	-	-	15 mm/30mm	continuous



## ABSOLUTE ROTARY ENCODER SSI

### Minimum (mechanical) lifetime

Flange	Lifetime in 10 <sup>8</sup> revolutions with F <sub>a</sub> / F <sub>r</sub>		
	40 N / 60 N	40 N / 80 N	40 N / 110 N
C10 (Clamp flange 10 x 20)	247	104	40
S10 (Synchro flange 10 x 20)	216	91	35
S6 (Synchro flange 6 x 10) without shaft sealing	713	301	116

S6 (Synchro flange 6 x 10) with shaft sealing: max. 20 N axial, 80 N radial

### Environmental Conditions

Operating temperature	- 40 .. + 85°C *
Storage temperature	- 40 .. + 85°C *
Humidity	98 % (without liquid state)
Protection Class (EN 60529)	Casing side: IP 65
	Shaft side: IP 64 (optional with shaft sealing: IP66)
Protection Class (EN 60529) Hollow shaft	IP 64

\* Cable exit: -30 ... + 70 °C (static), -5 ... + 70 °C (flexing)

### Interface

Synchronous Serial Interface (SSI)

Driver	Driver meets EIA standard RS 422; transmission rates up to 10 MBit/s
Transfer	Transfer distance up to 1,200 m
Transmission	Balanced transmission provides high noise immunity
Pair lines	Shielded and twisted pair lines are essential to attain extremely high noise immunity
Interface	For a detailed description of the synchronous-serial interface (SSI) refer to introduction section.
Optional	Built-in RS 422 interface for bus mode (strobe-function). Up to 10 encoders can be used on the same data line !

Detailed description for SSI-Interface under [www.scancon.dk](http://www.scancon.dk)



## ABSOLUTE ROTARY ENCODER SSI

### Reading position value (Single transfer)

Behind the lsb two "0" follow, on 13 or 15 bit per revolution only one "0" follow.

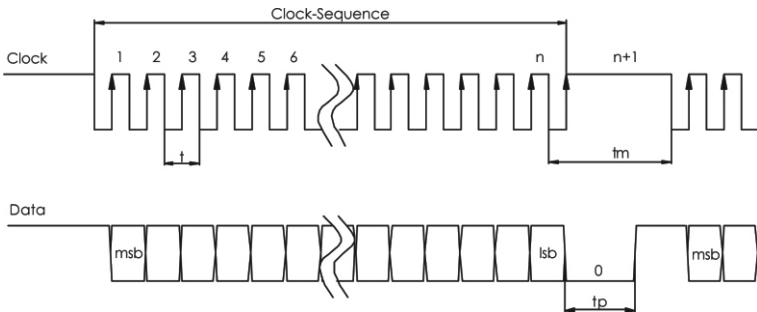

### Reading position value multiple times (Multiple transfer)

SCANCON SSI encoders use the "multiple transfer" to read a position value multiple times. If a pause does not come after the clock sequence, the encoder will repeat the position value. This will continue until the proper pause ( $t_m$ ) occurs. The multiple transfer of the same data allows the control system to recognize transfer errors.

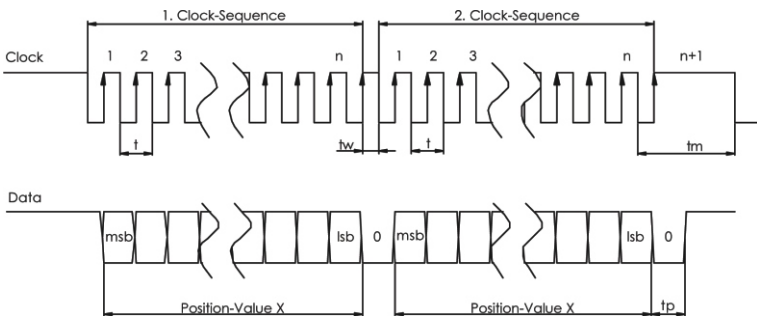

Some PLC's require a "0" after the last transmitted bit (lsb). For this reason, the "multiple transfer" feature on single turn encoders with more than 13 bits can be disabled (optional) for PLC's that provide only the SSI-formats 13, 21 and 25 bits. This feature is factory set and must be requested when ordering.

## ABSOLUTE ROTARY ENCODER SSI

**Preset function (only for interface S1, S3 or S4)**

Preset value = 0 will be set after falling edge or end of pushing preset push-button (only version S4). This function should be only used on a standstill shaft.

**Preset push-button (see sketch, only interface S4)**

LED Display	Function
Green	On = power supply is connect to the encoder. Turn off during pushing the preset push-button.
Red	On = Alarm message if LED reaches a lower light level (with normal data output) or memory failure (data bits will set continuous to "high")

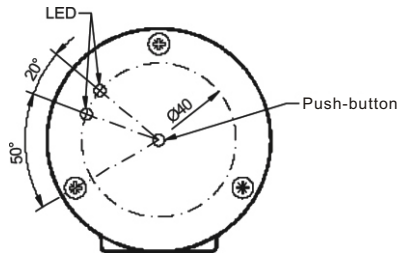

**Incremental outputs (only in interface S2 or S3)**

Output of 1024 pulse per turn i.e. to grasp the velocity for a motor control system. Signal A and B are shifted to detect the rotary direction.

No. of increments	1024
Signals	Channel A, /A, B, /B
Driver	Line driver RS 422
Phase offset	90° between A and B (< 10%)
Output frequency	Max. 800 kHz

## ABSOLUTE ROTARY ENCODER SSI

### Electrical connection

Interface	12 pol. Connector Pin-Nr.				Wire end	
	SL	S1 / S4			SL	S1
Clock -	1	1			Yellow	Yellow
Clock +	2	2			Green	Green
Data +	3	3			Grey	Grey
Data -	4	4			Pink	Pink
Complement	8	8			Red	Red
+ U <sub>s</sub> = 10-30 V	11	11			Brown	Brown
GND	12	12			White	White
Preset	-	9				Black
A	-					
/A	-					
B	-					
/B	-					
Shielding	-	-			Shielding	Shielding

Pinning encoder (male)

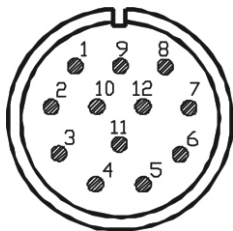

Complement input		Encoder counting direction for clockwise rotation (looking onto the shaft)
Function	Level	
Direction of rotation	0 (Input = N.C. * or GND)	Up
	1 (Input = + U <sub>s</sub> or ≥ 4,5 V)	Down
Preset input (only for interface S1, S3, S4)		Output position value
Function	Level	
Preset value = 0	0 (Input = N.C. * or GND)	
	1 (Input = + U <sub>s</sub> or ≥ 4,5 V)	Set on falling edge (min. 100 ms)

\* no ledge on connector disposed

## ABSOLUTE ROTARY ENCODER SSI

### Mechanical Drawings

#### Synchro flange (S)

Available two versions

Synchro flange	d / mm	l / mm
Version S06	6 <sub>h6</sub>	10
Version S10	10 <sub>h8</sub>	20

Cable exit (Cable = Ø 8 mm )

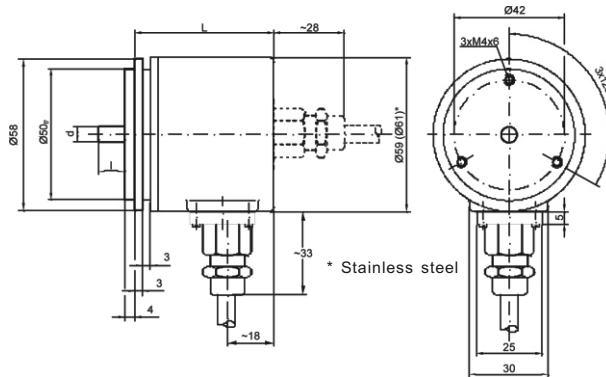

12 pol. Connector (for Ø 6-9 mm cable, stainless steel\*  
drawings on request)

		L
Single-Turn	Axial	42
	Radial / axial*	53
Multi-Turn	Axial	53
	Radial	53

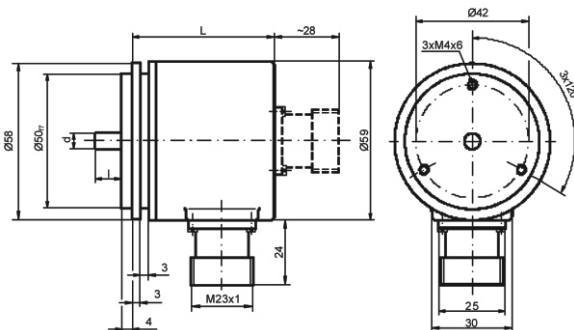

## ABSOLUTE ROTARY ENCODER SSI

### Clamp flange (C10)

Cable exit (Cable =  $\varnothing$  8 mm)

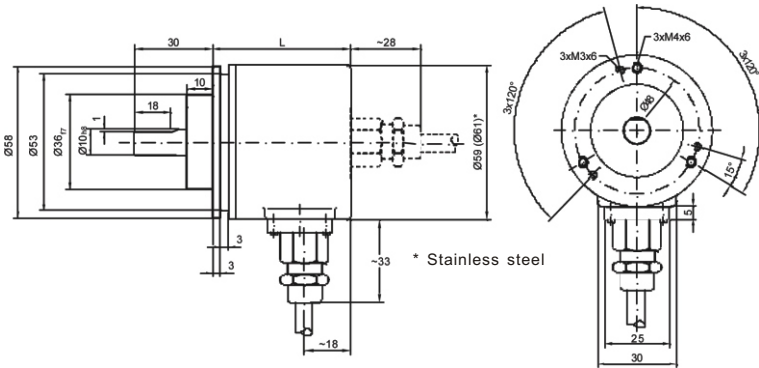

12 pol. Connector (for  $\varnothing$  6-9 mm cable, stainless steel\* drawings on request)

		L
Single-Turn	Axial	42
	Radial / axial*	53
Multi-Turn	Axial	53
	Radial	53

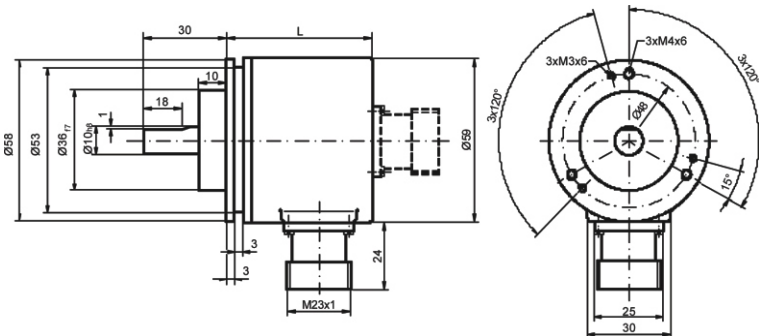



## ABSOLUTE ROTARY ENCODER SSI

### Hollow shaft (T)

12 pol. Connector (for  $\varnothing$  6-9 mm cable)

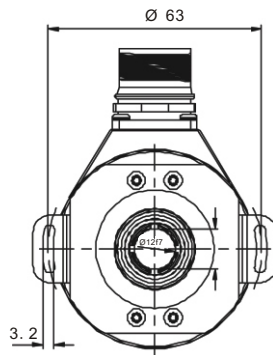
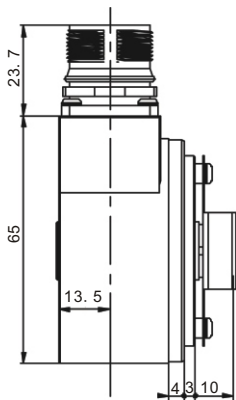

Cable exit (Cable =  $\varnothing$  8 mm)

	L
Single-Turn	47
Multi-Turn	60

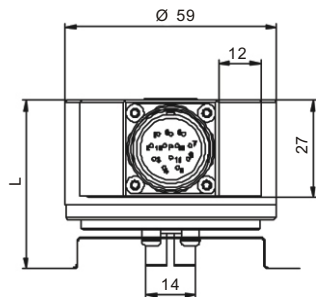
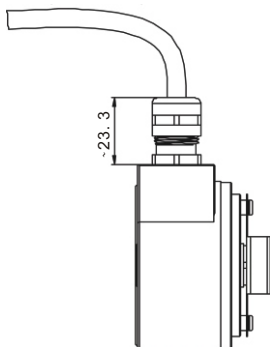

Mounting instruction see on the next side

## ABSOLUTE ROTARY ENCODER SSI

### Blind hollow shaft (B)

With cable exit available too. See drawing clamp (Stainless steel\* and cable exit drawings on request) flange.

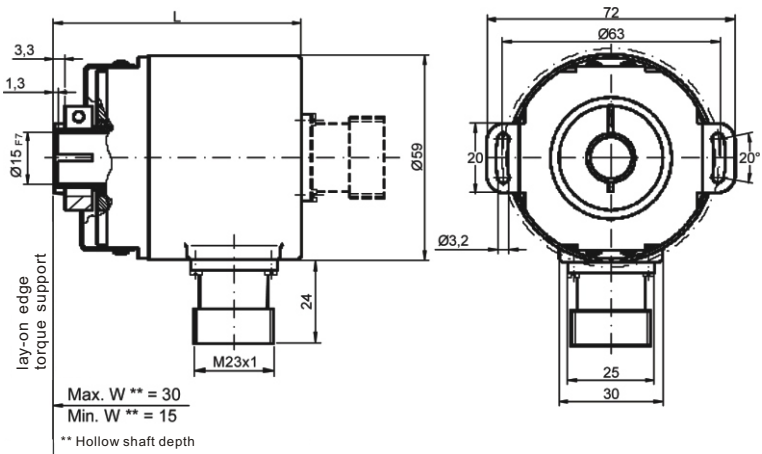

		L
Single-Turn	Axial	61
	Radial / axial*	72
Multi-Turn	Axial	72
	Radial	72

### Mounting instructions

The clamp ring should only be tightened if the shaft of the driving element is inserted into the hollow shaft.

The diameter of the blind hollow shaft can be reduced to different diameters (see accessories) by using an adapter (this reducing adapter can be pushed into the hollow shaft).

Maximum radial and axial misalignment of the drive shaft:

	Axial	Radial
Static	± 0.3 mm	± 0.5 mm
Dynamic	± 0.1 mm	± 0.2 mm



ABSOLUTE ROTARY ENCODER  
SSI

**Part Numbering System**  
**Absolute Rotary Encoder -- SSI**

( Example: SAG - SL00G - 1213 - C100 – CRW )

Part Number: **SAG -** \_ \_ **00** \_ - \_ - \_ - \_ - \_ - \_ -

**Description**

<b>Interface</b>	SSI	<b>SL</b>					
	Preset ( <i>option</i> )	S1					
<b>Version</b>			<b>00</b>				
<b>Code</b>	Gray			<b>G</b>			
	Binary			B			
<b>Revolutions (in Bits)</b>	Single turn (1 revolution)					<b>00</b>	
	Multi turn (4,096 revolutions)					<b>12</b>	
	Multi turn (16,384 revolutions) ( <i>option</i> )					14	
<b>Steps per Revolution (in Bits)</b>	4,096 steps (0.09° deg./step)						<b>12</b>
	8,192 steps (0.04° deg./step)						<b>13</b>
	65,536 steps (0.005° deg./step) ( <i>option</i> )						16
<b>Flange</b>	Clamp flange						<b>C</b>
	Synchro flange						<b>S</b>
	Blind hollow shaft						<b>B</b>
<b>Shaft diameter</b>	06 mm						<b>06</b>
	10 mm						<b>10</b>
	15 mm (Blind hollow shaft)						<b>15</b>
<b>Mechanical options</b>	Without						<b>O</b>
	Shaft sealing (IP66) ( <i>option</i> )						S
	Stainless Steel ( <i>option</i> )						V
	Customized ( <i>option</i> )						C
<b>Connection</b>	Connector, axial						<b>PAL</b>
	Connector, radial						<b>PRL</b>
	1m cable exit, axial						<b>CAW</b>
	1m cable exit, radial *						<b>CRW</b>

Standard offering shown in bold

\* unavailable in stainless steel



## ABSOLUTE ROTARY ENCODER SSI

### Accessories and Documentation

Description		Type
Connector, counterpart	Circular connector, 12 pins	PAL
Cable for 1KG/PAL	4 x 2 x 0,14 mm <sup>2</sup> + 2 x 0,5 mm <sup>2</sup>	ST-K4P/G
Shaft coupling *	Drilling: 10 mm	GS 10
	Drilling: 6 mm	GS 06
Clamp disc *	4 pcs. / AWC	SP 15
Clamp ring *	2 pcs. / AWC	SP H
Reducing adapter ** (Blind shaft)	15 mm to 12 mm	RR12
	15 mm to 11 mm	RR11
	15 mm to 10 mm	RR10
	15 mm to 8 mm	RR8
Reducing adapter ** (Continuous hollow shaft)	12 mm to 11 mm	RRT11
	12 mm to 10 mm	RRT10
	12 mm to 8 mm	RRT8

\* not for hollow shaft

\*\* only for hollow shaft, in stainless steel available too

We do not assume responsibility for technical inaccuracies or omissions. Specifications are subject to change without notice.