



Stainless steel



up to IP 67

ELECTRICAL SPECIFICATIONS

At +25°C	
Output waveform	Incremental (A, B)
Zero or index pulse	(Z) one pr./rev.
Output	Totempole
Supply-voltage (Vin)	Min. 4,5V to Max. 30V * Reverse polarity protection
Current (no load)	Max. 45 mA
Max. load pr. output	30 mA - (Short circuit protected)*
V _{Out low}	Max. 500 mV @ I = 10mA
Operating temp.	- 40°C to + 75°C
Storage temp.	- 40°C to + 75°C
Max. pulse frequency	300 kHz*
V _{out high}	Min. (Vin -0,6) @ I = -10mA Min. (Vin -1,3) @ I = -25mA
Cable data	8 leads (0,14 mm ²)pairtwisted/shielded
Output signals	Standard, Inverted, Differential (RS-422A compatible)
EMC certified acc. to	EN 50081-1 and EN 50082-2
EEEx certified acc. To	EN 50014 and EN 50018 and 94 / 9 / EC (ATEX)
* = It is not recommended to combine max value for all 3 parameters	

OUTPUT WAVEFORM



Rotation: Clockwise (cw) from shaftside

(inv = inverted channels)

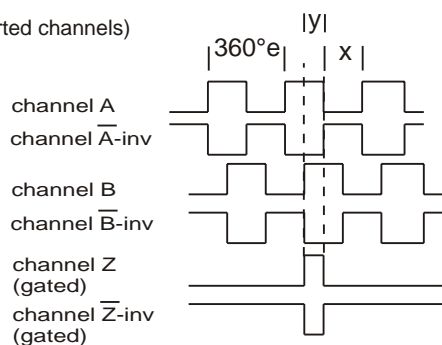

X = 180°e ± 36°e and Y = 90°e ± 18°e
Z puls: Gated with A and B (standard)

Options: TTL or HTL compatible. Open Collector NPN or PNP
Gated Z-puls or none-gated Z-puls.
View more Output options 52 - page 1

CHARACTERISTICS

ENCODER TYPE	Shaft encoder for mining
APPROVAL	CE 0539 I M2 Ex d I/II C T6 II 2 G/D Ex d IIc T6
SMD - TECHNOLOGY	Strong compact electronics
HIGH IP-RATING	Std. IP 66 (option IP67)
LOW CURRENT CONSUMPTION	To be connected directly to PLC'S and counters
SHORT CIRCUIT PROTECTION	Thermal shut down at 155°C
WIDE SUPPLY RANGE	Min. 4,5V to max. 30V
STRONG MEC. CONSTRUCTION	Based on 2 precision ball bearings, for harsh industrial environments

MECHANICAL SPECIFICATIONS

Weight	About 1,325 kg
Materials : Housing	Stainless steel (AISI303) (A2)
Shaft	Stainless steel (AISI303) (A2)
Bearings	Lifetime lubricated ball bearings
Shaft dimensions	ø10 mm
Shaft loads	Axial max. 50 N Radial max. 50 N
Max. rev.	1500 rev./min. (IP 66 = 3000rev/min)
IP-rating	Standard IP 67
Start torque	IP 66 < 0,05 Nm at 25°C IP 67 < 0,2 Nm at 25°C
Mass moment of inertia	35 gcm ²
Max. shock	100 G/11 ms
Bump	10 G - 16 ms (1000 x 3 Axis)
Vibration	(10 - 2000 Hz)/10 G

MECHANICAL DIMENSIONS

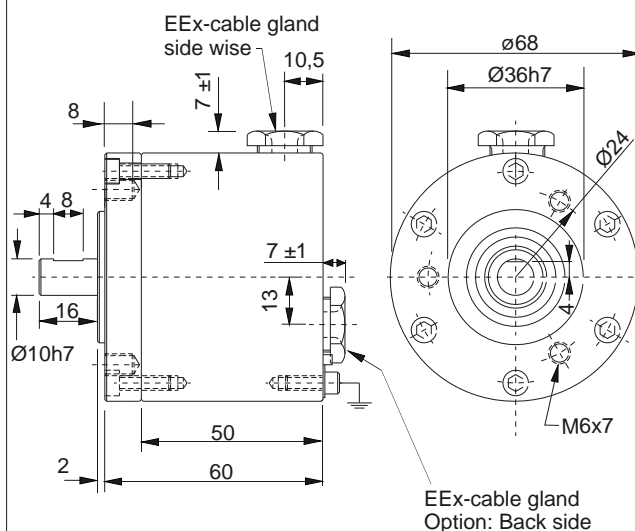

Option: Cable protection with hydraulic hose - side wise or back side

OUTPUT CIRCUIT

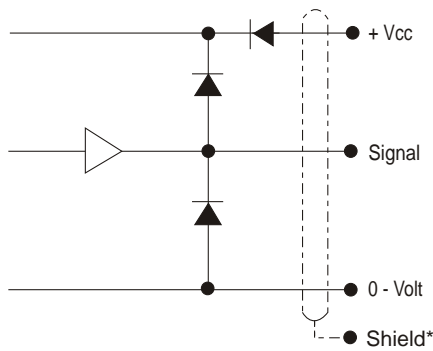

* Shield connected to housing

PULSES/REV.

1	16	50	125	400	1000	2500
2	20	60	150	455	1024	3000
5	25	64	180	500	1131	3600
6	30	75	200	600	1250	4000
8	32	80	250	635	1500	4096
10	36	90	300	720	2000	5000
15	40	100	360	800	2048	9000

ORDERING CODES

	Options	Ordering codes
Pulses pr. rev.:	No. of pulses	XXXXX
Material:	Aluminum	AL
Output signal:	Normal, Standard, A, B, Z (3 channel)	N
	Inverted (A-inv, B-inv, Z-inv)	I
	Differential: A, B, Z and A-inv, B-inv, Z-inv (6 channel)	D
	Line driver OL 7272 for extra long cable, up to 100 meters (Differential)	M
	Line driver chip 26C31 (V out low < 0,4 V) (RS-422A compatible @ 5V) Only 5 Volt (Differential)	L
Shaft dimensions:	∅10 mm	10
IP-rating:	IP 66	66
	IP 67	67
Length of cable:	Standard 1 meter	01
	No. of meters	XX
Cable take out:	Side-standard	SS
	Back-standard	BS
	Side for hydraulic hose	SH
	Back for hydraulic hose	BH
Face Mount:	20mm shaft length	A
	Flange type: standard	
	16mm shaft length	B
	Flange type : standard	
	27mm shaft length	C
	Flange type : standard	
	25mm shaft length	F
	Flange type : standard	

FACE MOUNT

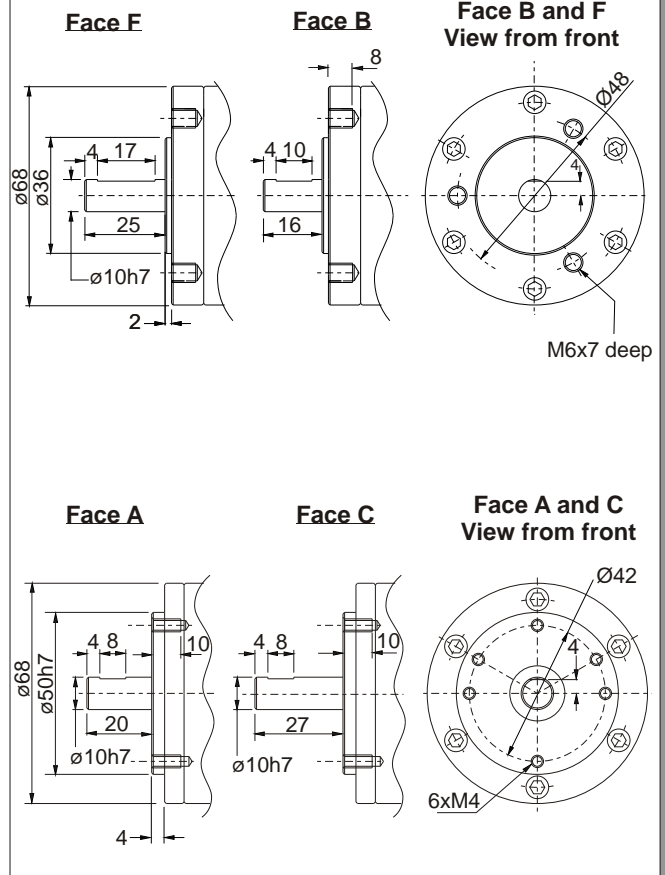

EEx CABLE TAKE OUT

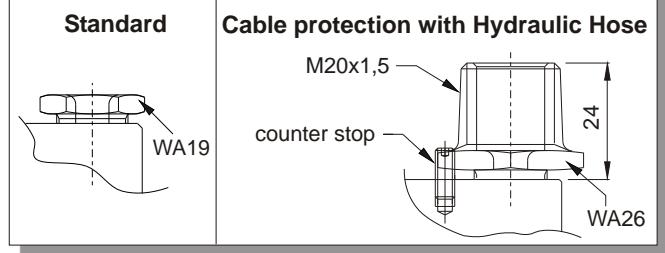

CONNECTIONS

Color code	Standard
Pink	Ch. A
Grey*	Ch. A Gnd
Green	Ch. B
Yellow*	Ch. B Gnd
White	Ch. Z
Brown*	Ch. Z Gnd
Red	Vcc
Blue*	Gnd

*Blue, grey, yellow and brown are internal connected

Color code	Differential
Pink	Ch. A
Grey	Ch. A inv.
Green	Ch. B
Yellow	Ch. B inv.
White	Ch. Z
Brown	Ch. Z inv.
Red	Vcc
Blue	Gnd

REXM-A



Pulses



Material



Output signal



Shaft



IP-rating



Length of cable



Cable take out



Face mount