

Absolute Rotary Encoder EXAG – Explosion Proof

Profibus-DP



Main Features

- Approval Ex II 2 G/D EEx d II C T6
- Heavy-duty industrial model
- Certified: By Profibus Trade Org., CE
- Interface: Profibus-DP
- DPV2-Functionality
- max. 65536 steps per revolution (16 Bit)
- max. 16384 revolutions (14 Bit)
- Code: Binary

Programmable Parameters

- Direction of rotation (complement)
- Resolution per revolution
- Total resolution
- Preset value
- Output of velocity
- Time base for velocity
- Software Limit Switches
- Parameters for isochronous mode

Mechanical Structure

- Ex-proof, flameproof enclosure
- Flange and housing of Aluminum
- Shaft of stainless steel
- Precision ball bearings with sealing or cover rings
- Code disc made of unbreakable and durable plastic

Electrical Features

- Address setting / connection via connection cap
- 400 million write cycles
- Temperature insensitive IR-opto-receiver-ASIC with integrated signal conditioning
- Polarity inversion protection
- Over-voltage-peak protection

SCANCON A/S

Tranevang 1, 3450 Allerød, Denmark
Tel: +45 48172702 Fax: +45 48172284
e-mail: info@scancon.dk
www.scancon.dk or www.scancon.cn



Absolute Rotary Encoder EXAG – Explosion Proof

Profibus-DP

Technical Data

Electrical Data

Interface	Line-driver according to RS 485, galvanically isolated by opto-couplers
Transmission rate	max. 12 MBaud
Device addressing	Adjustable by rotary switches in connection cap
Supply voltage	10 - 30 V DC (absolute limits) *
Current consumption	max. 230 mA with 10 V DC, max. 100 mA with 24 V DC
Power consumption	max. 2.5 Watts
Step frequency LSB	800 kHz
Accuracy of division	± ½ LSB (12 bit), ± 2 LSB (16 bit)
EMC	Emitted interference: EN 61000-6-4
	Noise immunity: EN 61000-6-2
Electrical lifetime	> 10 ⁵ h

* Supply voltage according to EN 50 178 (safety extra-low voltage)

Mechanical Data

Housing	Aluminum	
Max. shaft loading	Axial 50 N, radial 50 N	
Inertia of rotor	≤ 35 gcm ²	
Friction torque	IP65	≤ 0.05 Nm at 25°C
	IP67	≤ 0.2 Nm at 25°C
RPM max.	IP65	3,000 RPM
	IP54	6,000 RPM
	IP67	1,200 RPM
Shock (EN 60068-2-27)	≤ 100 g (halfsine, 11 ms)	
Vibration (EN 60068-2-6)	≤ 10 g (10 Hz ... 2,000 Hz)	
Weight (standard version)	Approx. 1200 g	
Flange		
Clamp (C)		
Shaft diameter	10 mm	
Shaft length	20 mm	

Environmental Conditions

Operating temperature	- 40 .. + 70°C
Storage temperature	- 40 .. + 85 °C
Humidity	98 % (without liquid state)
Protection class (EN 60529)	IP 65 (others on request)

Absolute Rotary Encoder EXAG – Explosion Proof

Profibus-DP

Note:

For ambient temperatures below -10°C and above $+60^{\circ}\text{C}$ use field wiring suitable for both minimum and maximum ambient temperature.

Ex-Protection

SCANCON encoders type series EXAG are classified according to  II 2 G/D EEx d II C T6:

	II	2	G/D	EEx	d	II	C	T6
Temperature Class T6: Maximum surface temperature: $+85^{\circ}\text{C}$								
Explosion Sub-Group C: Hydrogen (H_2) , Acetylene (C_2H_2), Carbon Disulfide (CS_2)								
Explosion Group: for all areas except for mining								
Method of protection: flameproof enclosure								
Device in compliance with EN50014 and EN50018								
Application Area: permitted for gas und dust								
Equipment-Category 2: permitted for zone 1 / zone 21								
Equipment-Group II: for all applications except for mining								
Ex-Proof Device								

Absolute Rotary Encoder EXAG – Explosion Proof

Profibus-DP

Interface

Installation

The rotary encoder is connected with two or three cables, depending on whether the power supply is integrated into the bus cable or connected separately. If the power supply is integrated into the bus cable one of the cable glands can be fitted with a plug (unused cable entries have to be closed with a blind plug-> accessories). The connection cap has two cable glands for cable diameters from 8 – 9.5 mm (for bus cable) and one cable gland for cable diameter 6.5 – 8 mm (power supply).

Follow the instructions in the installation manual carefully, otherwise the ATEX-certification will be repealed!

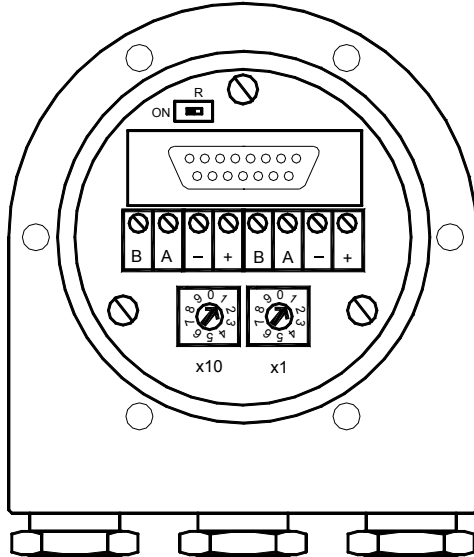

The Profibus-DP device address is set by user-friendly rotary switches in the connection cap. Allowed addresses are between 1 and 99, each can only be used once. The connection cap can be opened for installation by removing the six cap screws.

Termination resistors are integrated in the connection cap. These must be switched on if the encoder is connected at the end or the beginning of the bus.



Connecting the data line and the power supply

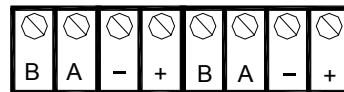

Clamp	Description
B (left)	Bus line B (Bus in)
A (left)	Bus line A (Bus in)
-	0 V
+	10 – 30 V
B (right)	Bus line B (Bus out)
A (right)	Bus line A (Bus out)
-	0 V
+	10 – 30 V

The power supply has to be connected once (no matter which clamps). If the terminating resistor is switched on, the outgoing bus lines are disconnected.

A GSD-file is necessary for installing the encoder. The disc with the GSD-file and the detailed user manual can be ordered from SCANCON or downloaded from our homepage, www.scancon.dk

Absolute Rotary Encoder EXAG – Explosion Proof

Profibus-DP

Interface

Programmable Parameters

The Profibus-DP interface supports CLASS 1 and CLASS 2 functionality according to the encoder profile *. In addition to these functions the GSD-file supports further features, for example software

limit switches. Further more, the following encoder parameters can be programmed directly via the Profibus-DP network without any extra device:

Counting Direction	This parameter counting direction defines whether the output code increases or decreases when the shaft rotates clockwise.
Resolution per Revolution	The parameter 'resolution per revolution' is used to program the desired number of steps per revolution. Each value between 1 and the physical resolution per revolution can be programmed.
Total Resolution	This parameter is used to program the desired number of measuring units over the total measuring range. This value may not exceed the total physical resolution of the absolute rotary encoder.
Preset Value	The preset value is the desired position value, which should be reached at a certain physical position of the axis. The position value is set to the desired process value by the parameter preset.
Velocity	The implemented software can additionally deliver the current velocity. This value is transmitted in binary code, 16 Bit, in addition to the process value. It is possible to choose between four different units: steps per 10 ms, per 100 ms, per 1000 ms and revolutions per minute.
Software limit switches function	Two software limit switches can be set. If the position value falls below the lower or exceeds the higher limit switch, a status bit in the process value is set.
Teach-in (Online parameterization)	A special mode is available for commissioning phase of the device. This makes it possible to change parameters while the encoder is in data exchange mode. For continuous operation another mode is available in which the parameters are protected against unintentional changes.

* The Profibus-DP profile for encoder can be ordered from

Profibus Nutzerorganisation e.V.
(Profibus User-Organization)
Haid und Neu-Str. 7,
D-76131 Karlsruhe, Germany
with order-No. 3.062.

Absolute Rotary Encoder EXAG – Explosion Proof

Profibus-DP

Mechanical Drawings

Clamp flange (C)

Shaft

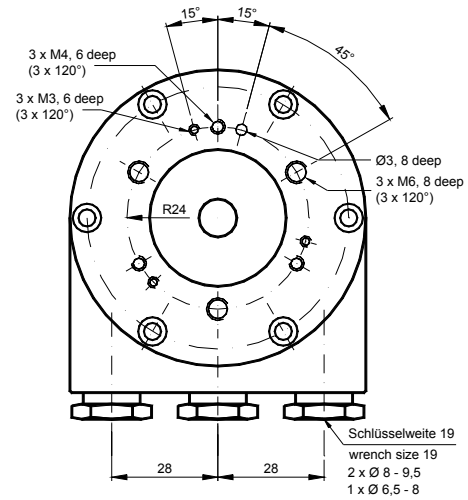
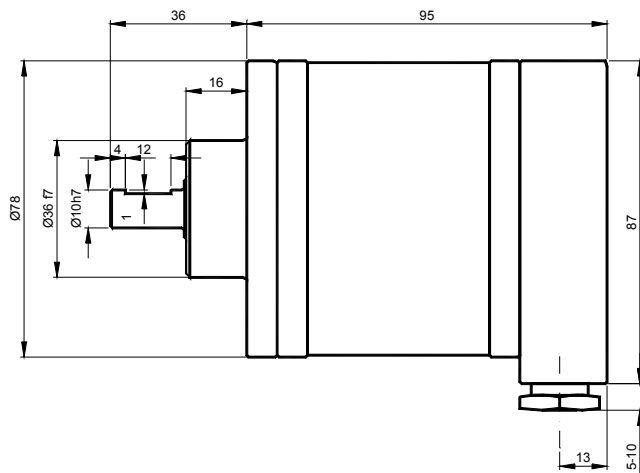

Hollow Shaft

