



Hollow through Shaft

CHARACTERISTICS

ENCODER TYPE	Hollow through shaft encoder
SMD - TECHNOLOGY	Strong compact electronics
HIGH IP-RATING	Std. IP 65
LOW CURRENT CONSUMPTION	To be connected directly to PLC'S and counters
SHORT CIRCUIT PROTECTION	Thermal shut down at 155°C
WIDE SUPPLY RANGE	Min. 4,5V to max. 30V
STRONG MEC. CONSTRUCTION	Based on 2 precision ball bearings, for harsh industrial environments

ELECTRICAL SPECIFICATIONS

At +25°C	
Output waveform	Incremental (A, B, Z and inverted)
Zero or index pulse	(Z) one pr./rev.
Output	Totempole (TP)
Supply-voltage (Vin)	Min 4,5V to Max. 30V * Reverse polarity protection
Current (no load)	Max. 45 mA
Max. load pr. output	30 mA - (Short circuit protected) *
V out low	Max. 500 mV @ I = 10 mA
Operating temp.	- 40°C to + 85°C
Storage temp.	- 40°C to + 85°C
Phase difference	300 kHz *
V out high	Min. (Vin -0,6) @ I = -10mA Min. (Vin -1,3) @ I = -25mA
Cable data	8 leads (0,14 mm ²)pairtwisted/shielded
Output signals	Standard, Inverted, Differential (RS-422A compatible @ 5V)
Certified acc. to	EN 50081-1 and EN 50082-2

* = It is not recommended to combine max. value for all 3 parameters

MECHANICAL SPECIFICATIONS

Weight	About 120 g
Materials : Housing	Aluminum
Shaft	Stainless steel
Bearings	Lifetime lubricated ball bearings
H. Shaft dimensions	ø6 mm ø8 mm
H. Shaft loads	Axial max. 20 N Radial max. 20 N
Max. rev.	6.000 rev./min.
IP-rating	Standard IP 65
Start torque	<0,1 Nm at 25°C
Mass moment of inertia	2,5 gcm ²
Max. shock	100 G/11 ms
Bump	10 G - 16 ms (1000 x 3 axis)
Vibration	(10 - 2000 Hz)/10G

OUTPUT CIRCUIT

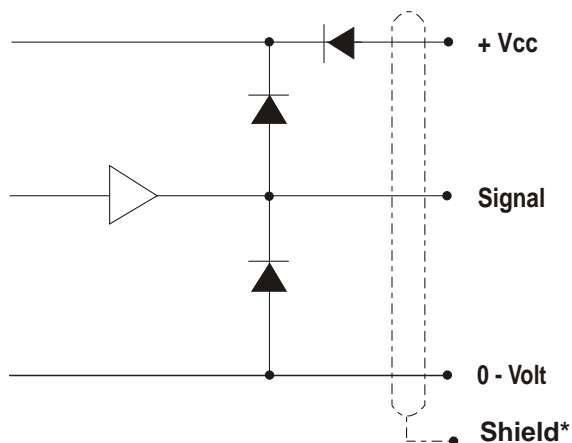

*Shield connected to housing

MECHANICAL DIMENSIONS

