

Scancon 2CEX-A



Introduction

ATEX certified incremental Encoder.

MECHANICAL SPECIFICATIONS

Material	Housing - seawater-proof aluminum anodized to 22 microns Shaft - Stainless steel Bearings - Lifetime lubricated ball bearings
Hollow Shaft Loads	axial maximum = 50N radial maximum = 50N
Max. rev.	3,000 rev./min.
IP-rating	Standard IP 64
Starting Torque	< 0,005 Nm at 25° C
Mass Moment of Inertia	40 g/cm ²
Shock	maximum 100G / 11 ms
Bump	10G - 16 ms (1000 X 3 axis)
Vibration	(10-2000Hz)/ 10G

ELECTRICAL SPECIFICATIONS

Output Waveform	Incremental (A, B, Z)
Output Signals	Standard Inverted Differential (RS-422A compatible)
Current No Load	45 mA
Maximum Load per Output	30 mA-(Short circuit protected)*
Supply Voltage	minimum 4.5 V to maximum 30 V (Reverse polarity protection)
V _{out} low	maximum 500 mV @ I = 10 mA
V _{out} high	minimum (Vin -0.6) @ I = -10 mA minimum (Vin -1.3) @ I = -25 mA
Operating Temp.	- 40°C to +75°C
Storage Temp.	- 40°C to +75°C

OUTPUT WAVEFORM

 CW Seen from shaft end

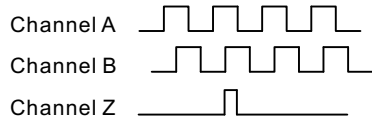

MECHANICAL DIMENSIONS

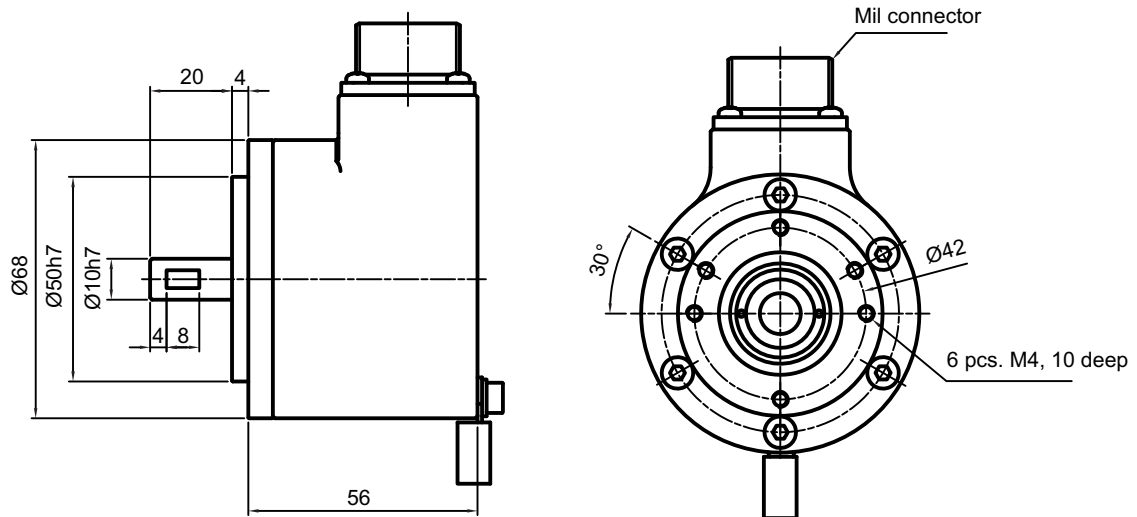

MIL - CONNECTOR

6 pin MIL

MS 3102A-14S-6P

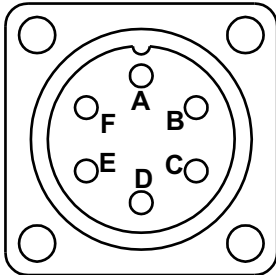

Encoder Receptical Connections

Pin	Function
A	0 volt
B	Vcc
C	Channel Z
D	Channel B
E	Channel A
F	NC

7 pin MIL

MS 3102A-16S-1P

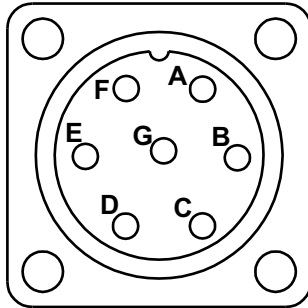

Encoder Receptical Connections

Pin	Function
A	Channel A
B	Channel B
C	Channel Z
D	+Vcc
E	NC
F	0 volt
G	NC

10 pin MIL

MS 3106-18A-1P

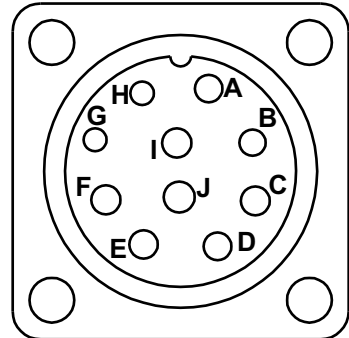

Encoder Receptical Connections

Pin	Function
A	Channel A
B	Channel B
C	Channel Z
D	+Vcc
E	NC
F	0-Volt
G	NC
H	Channel A not
I	Channel B not
J	Channel Z not

WARRANTY

Scancon A/S warrants against manufacturing defects for a period of 24 months from the date of manufacture. Product dimensions, weights and all product illustrations are approximate and may be modified without prior notice.

This warranty does not cover problems or consequences due to common usage (wear and tear) for which the product was designed. Nor does it cover product failures caused by improper installation or use, overloading, incorrect maintenance, or operation outside the product's specifications.

Detailed warranty information can be found in Scancon's Terms & Conditions

ORDERING CODES

Ordering Codes System Incremental Explosion Proof Encoder — 2CEX-A

Ordering Codes: 2CEX-A XXXX — X — XXXX — XX — XX — XX

Pulses pr. rev:	No. of pulses	XXXX					
	1 25 80 360 1000 3600						
	2 30 90 400 1024 4000						
	5 32 100 455 1131 4096						
	6 36 125 500 1250 5000						
	8 40 150 512 1500 9000						
	10 50 180 600 2000 10000						
	15 60 200 635 2048						
	16 64 250 720 2500						
	20 75 300 800 3000						
Output signal:	Normal, Standard, A, B, Z (3 channels)						N
	Inverted (A-inv, B-inv, Z-inv)						I
	Differential: A, B, Z and A-inv, B-inv, Z-inv (6 channels)						D
	Line driver OL 7272 for extra long cable, up to 100 meters (Differential)						M
	Line driver chip 26C31 (V out low <0,4 V) (RS-422A compatible @ 5V) Only 5 Volt (Differential)						L
Shaft dimensions:	Ø 10 mm					10	
IP-rating:	IP 64						64
Round Cable Length of cable:	Standard 1 meter No. of meters						01 XX
Round Cable take out:	Side-standard Back-standard Side for hydraulic hose Back for hydraulic hose						SS BS SH BH